

www.eetree.cn	
EETree Info & Tech Limited	
Sheet: /HS DAC/	
File: dac.kicad_sch	
Title: Analog Circuit Learning Kit	
Size: A4	Date: 2022-09-11
KiCad E.D.A. kicad (6.0.8)	Rev: V1.0
	Id: 4/4

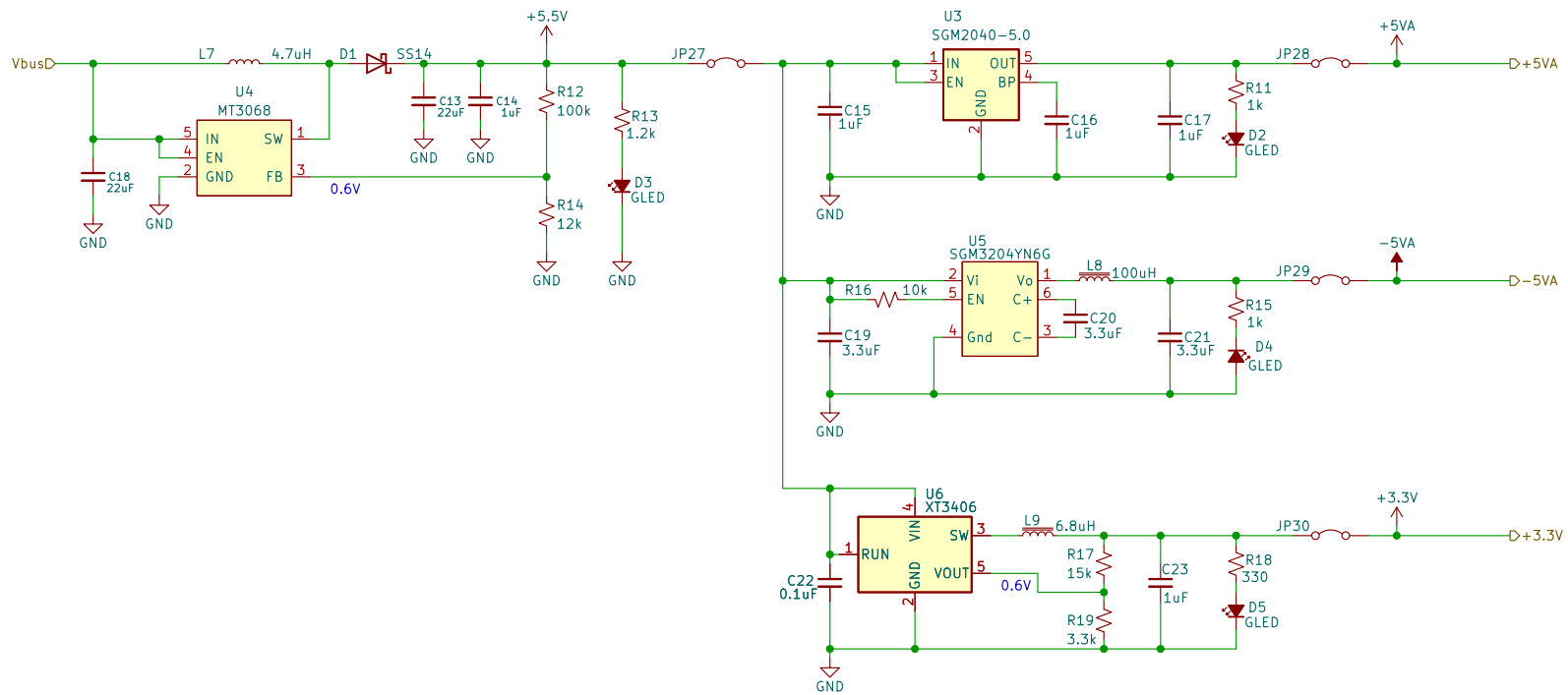

www.eetree.cn

EETree Info & Tech Limited

Sheet: /power supply/

File: ps.kicad_sch

Title: Analog Circuit Learning Kit

Size: A4 Date: 2022-09-11

KiCad E.D.A. kicad (6.0.8)

Rev: V1.0

Id: 5/4

